

FAIRCHILD MODEL 72 PNEUMATIC SUBMINIATURE REGULATOR

Installation, Operation and Maintenance Instructions

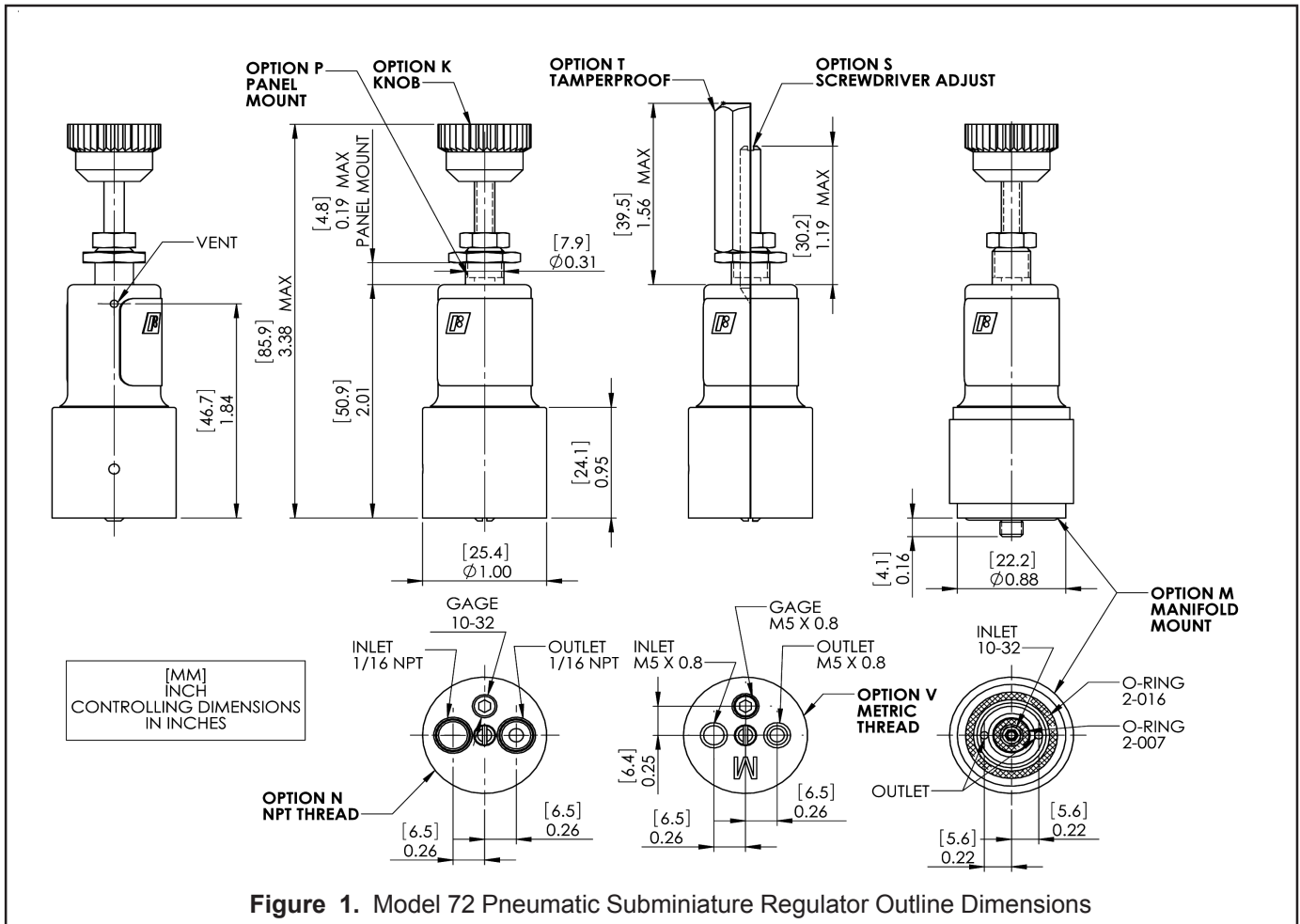

Figure 1. Model 72 Pneumatic Subminiature Regulator Outline Dimensions

INSTALLATION

Clean all pipelines to remove dirt and scale before installation.

For models 720*0N** and 720*0V**, apply a minimum amount of pipe compound to the male threads of the fitting only. **Do Not use Teflon tape as a sealant.** Start with the third thread back and work away from the end of the fitting to avoid contaminating the regulator. Install the regulator in the air line.

The inlet port is adjacent to the ball located on the side of the body. For model 720*0M** confirm the inner and outer O-Rings are in place, then thread

clockwise until the regulator seats against the manifold.

NOTE: Oil free air must be applied to the regulator. Use a filter to remove dirt and entrained liquid in the air line ahead of the regulator.

OPERATION

The Model 72 Pneumatic Subminiature Regulator provides precision control in limited space. The unit is available in five output ranges. For more information, see Figure 1.

MAINTENANCE

To clean the Model 72 regulator, use the following steps:

1. Shut off system pressure to the regulator to prevent air from escaping.
2. Remove the Model 72 regulator from the air line.
3. **WARNING:** The internal components of the model 72 are very small and can be damaged or lost easily; handle parts with care.
4. Remove the retaining screw from the center of bottom of the body and remove the valve and spring.

Wash the Valve with a solvent. Exercise care to prevent damage to valve facings. **Avoid solvents such as acetone, carbon tetrachloride and trichlorethylene.**

6. Replace the valve and spring carefully. Seal the retaining screw with Loctite 542.

Troubleshooting

Problem	Source	Solution
Leakage	<ul style="list-style-type: none"> • Body Screws • Diaphragm 	<ul style="list-style-type: none"> • Tighten the Bonnet to the Body • Ensure that the diaphragm is not punctured.
High Bleed	<ul style="list-style-type: none"> • Relief Seat 	<ul style="list-style-type: none"> • If contaminated, clean the source. • If damaged, install the service kit.

NOTE: If the standard maintenance procedure does not correct the problem, install the appropriate service kit.

For Models 720*0R, use service kit 20799-R**
For Models 720*0N, use service kit 20799-N**

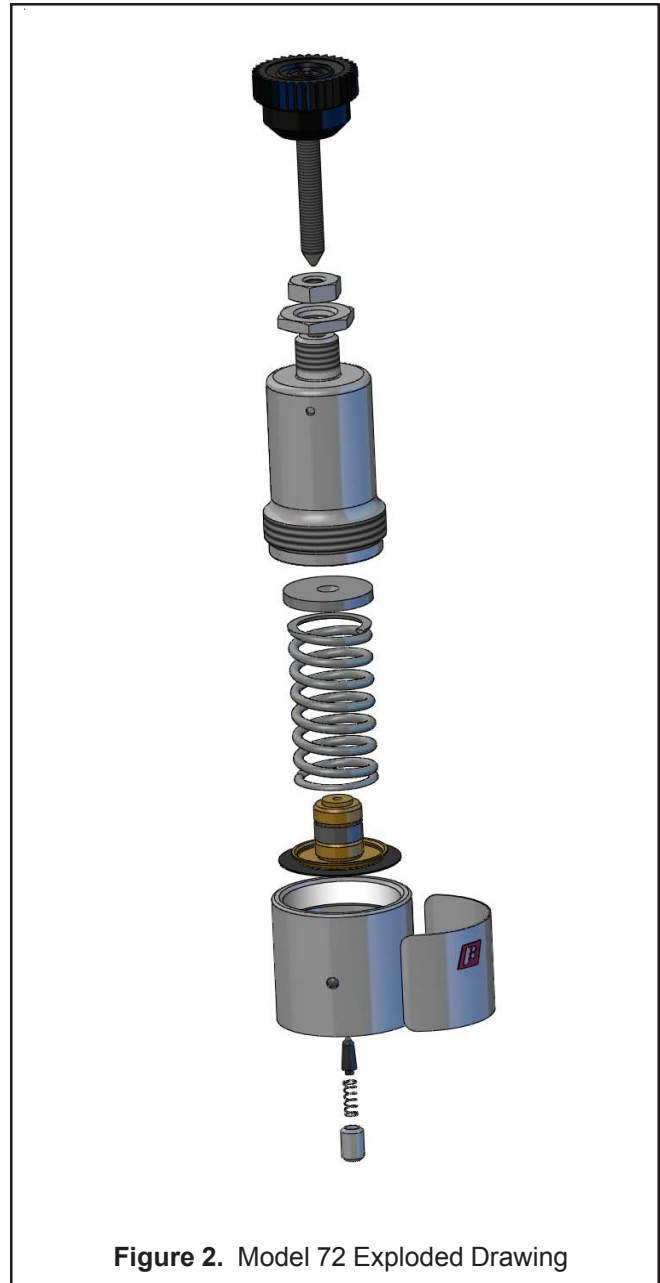

ISO 9001:2000
Certified

ISO 9001:2000
FM NO. 25571

Fairchild Industrial Products Company
 3920 West Point Blvd . • Winston-Salem, NC 27103
 phone: (336) 659-3400 • fax: (336) 659-9323
 sales@fairchildproducts.com • www.fairchildproducts.com

FAIRCHILD
precision pneumatic & motion control

IS-100072
Litho in USA
06/08